

Beam Section AF S150p

A modular steel framing system designed to make up supporting for cable trays, pipes, and support structures in heavy-duty building technology such as for industrial construction, plant construction, building catwalks, work platform etc.

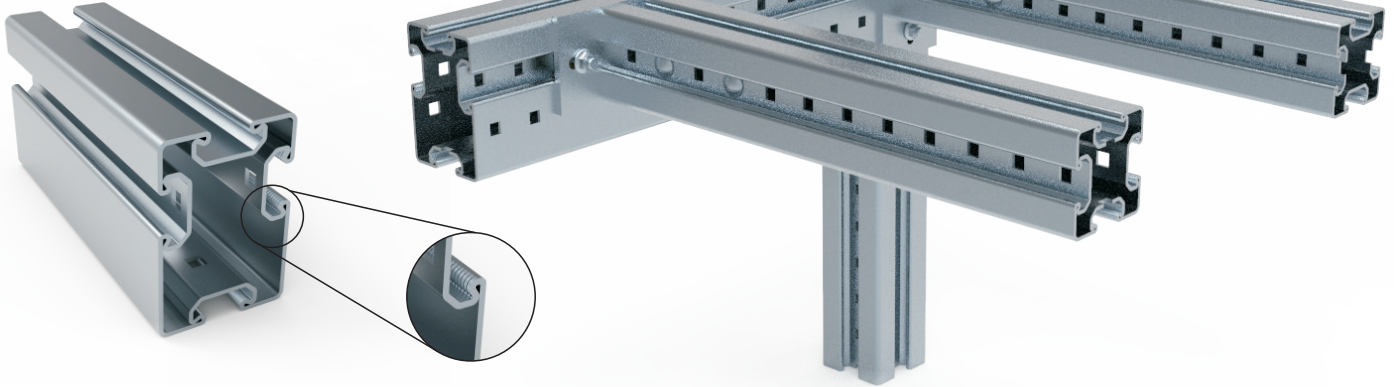

The Key Advantages

- A modular steel work support system provides an easy-to-install, adjustable, flexible solution for industrial and heavy commercial applications.
- Four-sided continuous fastening groove Beam Section AF S150p creates unique features of flexible arrangement of accessories and fastening components.
- Efficient installation due to the prefabricated structural components.
- Rectangular heavy-duty profile Beam Section AF S150p for support structures used in heavy-duty building technology, for industrial constructions, plant constructions and work platforms.
- **Plug-in component CC H100 & CB S100 designed to create an end plate at the open end of a Beam Section.**
- The high torsional resistance shape achieved by a totally closed profile design.
- The structural elements and pipe supports can be attached on all four-and-two-sided continuous fastening groove with virtually no placement restrictions.
- High tension T-head Bolt specially designed for quickly connecting all components.
- Saving time and money with the functional accessories that are matched to the section.
- High level hot-dipped galvanized corrosion protection.
- Compatible with generic strut system.

Technical Data

- **Material Composition:**
Steel S275JR - EN 10025
- **Surface Finish:**
Hot-dipped galv. 55µm DIN EN ISO 1461

➤ Model and designs are patented by **EUFIFIX®**.

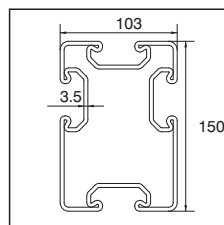
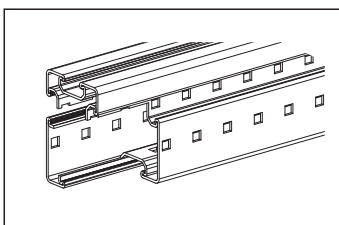

Section	Part-No.	Length	Thickness	Weight	Pack Size
		L [mm]	T [mm]	[kg/pc]	[pcs]
AF S150p	21115103	3,000	3.5	62.58	1
AF S150p	21115106	6,000	3.5	125.16	1

Overview Technical Values

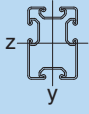
Section 	Available T-head bolt	Section Weight [kg/m]	Cross-section [cm²]	Material yield strength [Mpa]	Elasticity Modulus [Gpa]	Shear Modulus [Gpa]	Moment of inertia		Section modulus		Radius of Gyration	
							I _y [cm⁴]	I _z [cm⁴]	W _y [cm³]	W _z [cm³]	R _y [cm]	R _z [cm]
AF S150p	M12	20.9	15.39	275	210	81	673.46	336.88	89.79	67.38	5.11	3.62

Max. permissible point load [N]

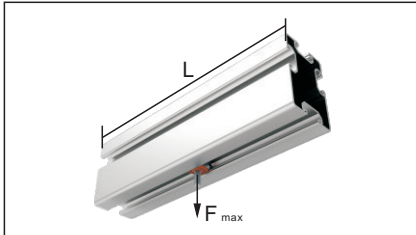

Length [mm]	Max. permissible point load Y side [N]	Max. permissible point load Z side [N]
500	8000	8000

Max. load capacities [N]

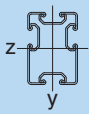
Section 	Case1 L[m]				Case2 L[m]				Case3 L[m]				Case4 L[m]			
	0.5	1.0	1.5	2.0	0.5	1.0	1.5	2.0	0.5	1.0	1.5	2.0	0.5	1.0	1.5	2.0
AF S150p-F _y	107,080	53,540	35,690	26,770	80,310	40,160	26,770	20,080	53,540	26,770	17,850	13,390	44,620	22,310	14,870	11,150
AF S150p-F _z	144,090	72,040	48,030	36,020	108,060	54,030	36,020	27,020	72,040	36,020	24,010	18,010	60,040	30,020	20,010	15,010

- At the stated values, the permissible steel stress of 160 N/mm² must not exceed and the maximum deflection under load L/200 must be taken into its own weight account.
- Load capacity values are valid for primarily static load.

