

### Cross Connector CC/CCE H100

Part of a modular system for supporting cable trays, pipes and miscellaneous secondary steel works. Absolutely reliable, easy-assembly solution without welding for use in industries (e.g. pharmaceuticals, refineries, power plants, etc.) and commerce.

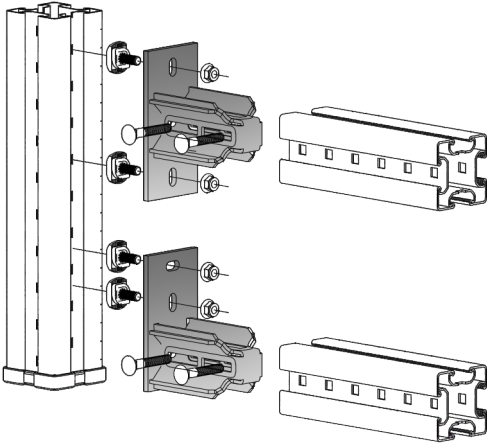

#### The Key Advantages

- In connection with Beam Section AF S100, Cantilever Bracket CB S100, or Beam Bracket BB S100.
- Smart shape connection tongue designed provides clean surface connection that allows the use of whole section area without interfering screws and plates.
- Any cut length of the Beam Section can be achieved.
- Cross Connector CCE allows a flush corner to the under side of the profile.
- Secure positive-fit corner connection of Beam Section, Cantilever Bracket, and Beam Bracket through insertion of the connector into the support profile.
- Power transmission of forces and moments through positive locking.

- Vibration-proof screw connection with self-locking nuts.
- High level hot-dipped galvanized corrosion protection.
- Provides an easy-to-install, adjustable, flexible solution for industrial and heavy commercial applications.

#### Technical Data

- **Material Composition:**  
Steel S275JR - EN 10025
- **Surface Finish:**  
Hot-dipped galv. 55µm DIN EN ISO 1461

➤ No single side cantilever possible, always support on both sides.

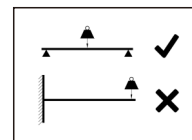
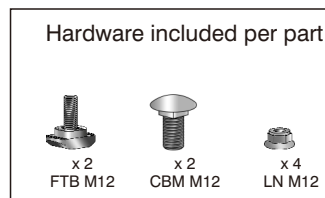
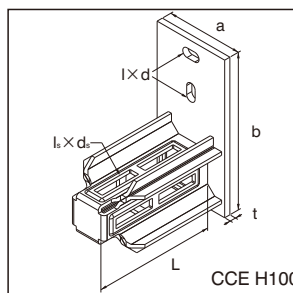
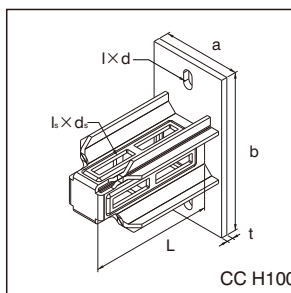

Type	Part-No.	Length	Plate a × b × t [mm]	Hole l × d [mm]	Hole l <sub>s</sub> × d <sub>s</sub> [mm]	Beam Section	Weight [kg/pc]	Pack Size [pcs]
CC H100	21201100	190	104 × 210 × 8	25 × 13	56 × 13	AF S100	4.00	1
CCE H100	21301100	190	104 × 195 × 8	25 × 13	56 × 13	AF S100	3.90	1

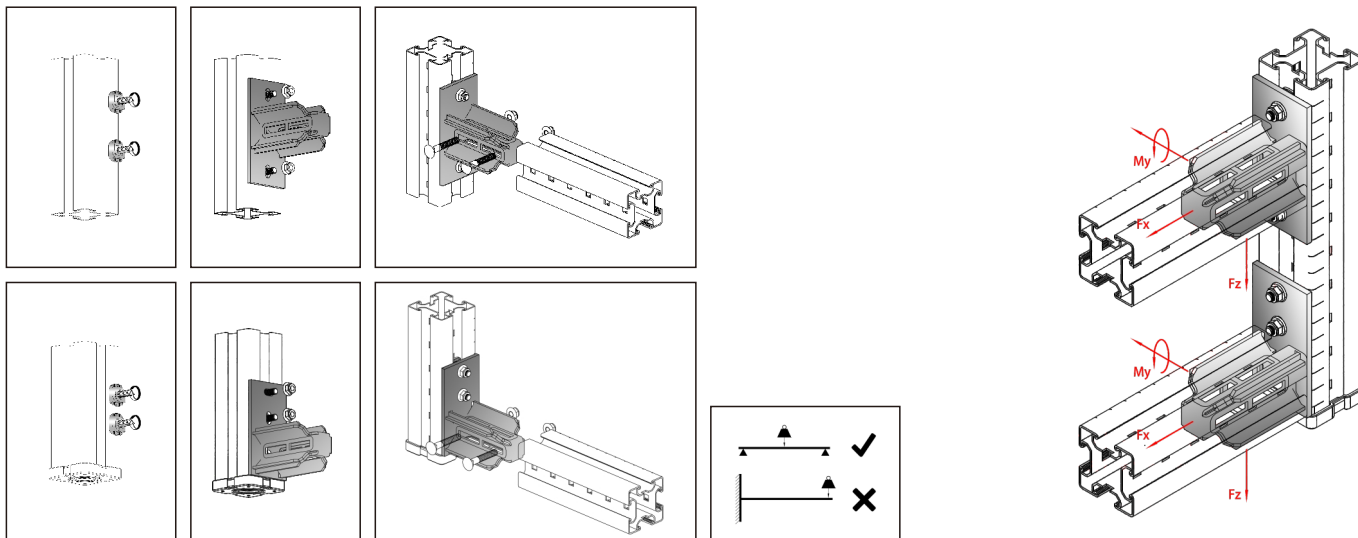

Type	± Fx [kN]	± Fy [kN]	± Fz [kN]	± My [kN]
CC H100	5.89	10.77	25.66	-
CCE H100	3.22	10.25	13.27	-

- At the stated values, the permissible steel stress of 160 N/mm<sup>2</sup> must not exceed and the maximum deflection under load L/200 must be taken into its own weight account.
- Load capacity values are valid for primarily static load.

