

Art. 506

Cantilever Bracket (For C-Channel)

Application/Advantages

- For pipe mounting directly on the wall, and for fastenings and structures on the ceiling and in the floor area.
- For high load-bearing construction applications.
- Fast and simple installation of pipe lines.
- Versatile usage possibilities for stepped lengths.
- Slots in the rail allow for versatile installation possibilities.
- Support brackets act as a cross member for fixing pipes in floor ducts.
- Can be used as a cantilever bracket for air ducts and cable trays.

Technical Data

- **Material:**
Steel 1.0332 acc. to DIN EN 10111
- **Zinc plating:**
Electro zinc plated, 8–12 µm

Note

- * Available at other bracket lengths subject to request.
- Please select the stainless steel range for outdoor use.

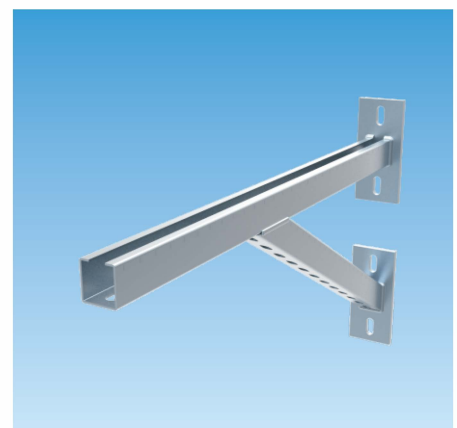
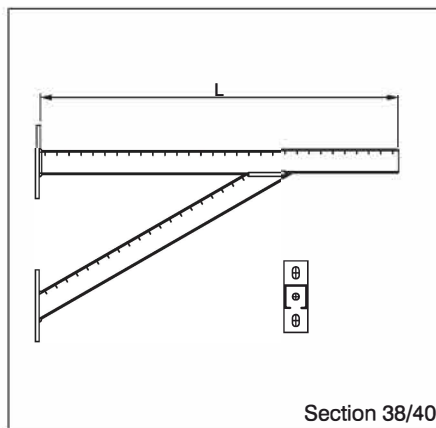
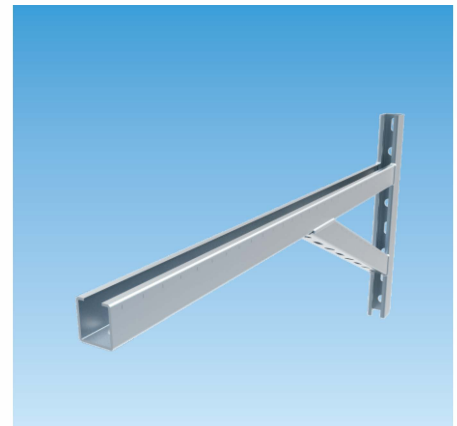
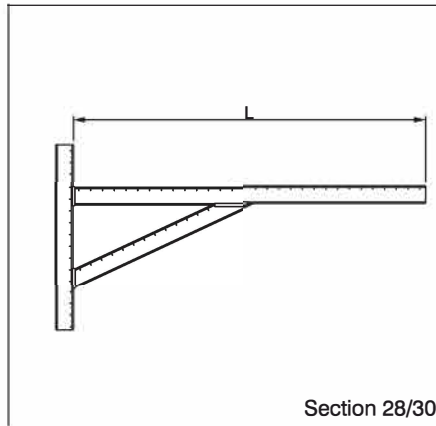

Article Number	Section [mm]	Length* L [mm]	Max. Rec. Load [N]				Weight [kg]	Pack Size ** [pcs]
0531 506 201	28/30/1.8	400	6570	3810	1650	1650	1.24	—
0531 506 202		600	4890	3320	1300	1300	1.74	—
0531 506 401	38/40/2.0	400	7730	4480	1830	1830	2.74	—
0531 506 402		500	4070	2160	1120	1020	3.09	—
0531 506 403		600	4890	3360	2030	1830	3.52	—
0531 506 404		700	3920	2140	1020	920	3.80	—

** Pack sizes are variable depending on customer's orders.