

Angled Pivot Joint APJ S50

Part of modular element with pivot joint as a bracing element for single-arm cantilevers conjunction with Beam Section AF S90/S100, traditional steel beam and building structure.

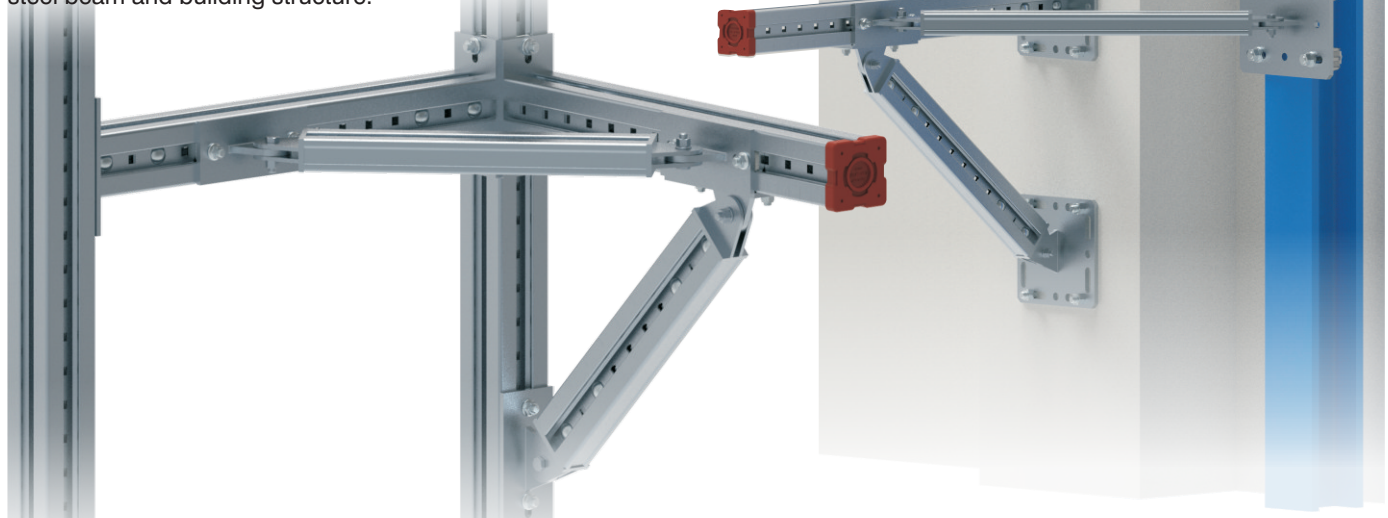

The Key Advantages

- Angled Pivot Joint APJ S50 for bracing of heavy constructions and to limit deflections.
- For the knee-brace reinforcing of all frame constructions.
- The pivot can be installed with angles from 25° to 155°.

Technical Data

- **Material Composition:**
Steel S275JR - EN 10025
- **Surface Finish:**
Hot-dipped galv. 55µm
DIN EN ISO 1461

| Type | Part-No. | Beam Section | Weight [kg/pc] | Pack Size [pcs] |
|-------------|----------|--------------|----------------|-----------------|
| APJ S50-90 | 11305090 | AF S50 | 3.3 | 1 |
| APJ S50-100 | 11305010 | AF S50 | 3.6 | 1 |
| APJ S50-A | 11505001 | AF S50 | 6.5 | 1 |
| APJ S50-B | 11505002 | AF S50 | 7.4 | 1 |
| APJ S50-C | 11505003 | AF S50 | 8.3 | 1 |
| APJ S50-D | 11505004 | AF S50 | 10.6 | 1 |
| APJV S50-B | 11605002 | AF S50 | 7.4 | 1 |
| APJV S50-C | 11605003 | AF S50 | 8.3 | 1 |
| APJV S50-D | 11605004 | AF S50 | 10.6 | 1 |

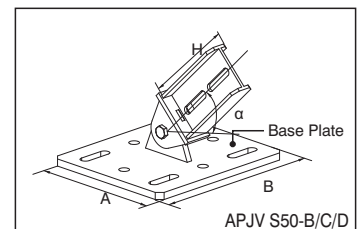
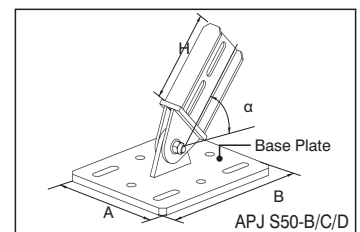
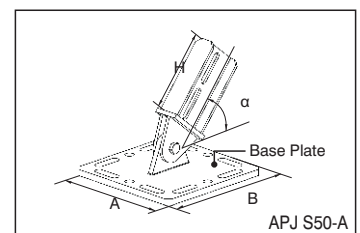
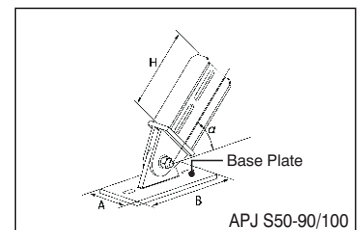

| Type | Plate AxBxs [mm] | Type of Base Plate | Conjunction With | | H [mm] | Angle α |
|-------------|------------------|--------------------|------------------|----------------------|--------|----------|
| | | | Beam Section | Flange of steel beam | | |
| APJ S50-90 | 94×204×12 | - | AF S90 | - | 150 | 25°~155° |
| APJ S50-100 | 104×210×12 | - | AF S100 | - | 150 | 25°~155° |
| APJ S50-A | 240×240×12 | A | - | 75~120 | 150 | 25°~155° |
| APJ S50-B | 280×240×12 | B | - | 121~160 | 150 | 25°~155° |
| APJ S50-C | 320×240×12 | C | - | 161~235 | 150 | 25°~155° |
| APJ S50-D | 420×240×12 | D | - | 235~300 | 150 | 25°~155° |
| APJV S50-B | 280×240×12 | B | - | 121~160 | 150 | 25°~155° |
| APJV S50-C | 320×240×12 | C | - | 161~235 | 150 | 25°~155° |
| APJV S50-D | 420×240×12 | D | - | 235~300 | 150 | 25°~155° |

Cutting length of support beam section between two joints

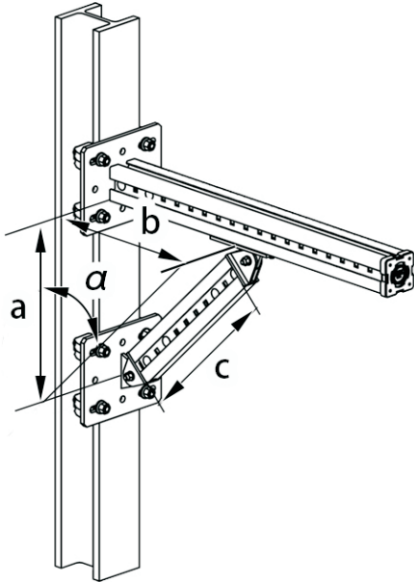

| | b [mm] | b [mm] | b [mm] | b [mm] | b [mm] | b [mm] | b [mm] |
|----------|--------|--------|--------|--------|--------|--------|--------|
| | 500 | 750 | 1000 | 1500 | 2000 | 2500 | 3000 |
| α | c [mm] | c [mm] | c [mm] | c [mm] | c [mm] | c [mm] | c [mm] |
| 25° | 1116.7 | 1708.2 | 2299.8 | 3482.9 | 4666.0 | 5849.1 | 7032.2 |
| 30° | 931.7 | 1431.7 | 1931.7 | 2931.7 | 3931.7 | 4931.7 | 5931.7 |
| 35° | 802.1 | 1237.9 | 1673.8 | 2545.5 | 3417.3 | 4289.0 | 5160.7 |
| 40° | 707.4 | 1096.4 | 1485.3 | 2263.1 | 3041.0 | 3818.9 | 4596.7 |
| 45° | 636.4 | 989.9 | 1343.5 | 2050.6 | 2757.7 | 3464.8 | 4171.9 |
| 50° | 582.3 | 908.6 | 1235.0 | 1887.7 | 2540.4 | 3193.1 | 3845.8 |
| 55° | 540.8 | 845.9 | 1151.1 | 1761.5 | 2371.9 | 2982.3 | 3592.7 |
| 60° | 509.0 | 797.7 | 1086.4 | 1663.7 | 2241.1 | 2818.5 | 3395.8 |
| 65° | 485.2 | 761.1 | 1036.9 | 1588.6 | 2140.3 | 2692.0 | 3243.7 |

a=vertical length from centerline of joint to bottom of profile at connection
 b=horizontal length of cantilever from connection to centerline of joint
 c=cutting length of support profile between two joints
 alpha=angle at the opposite of the vertical bracing

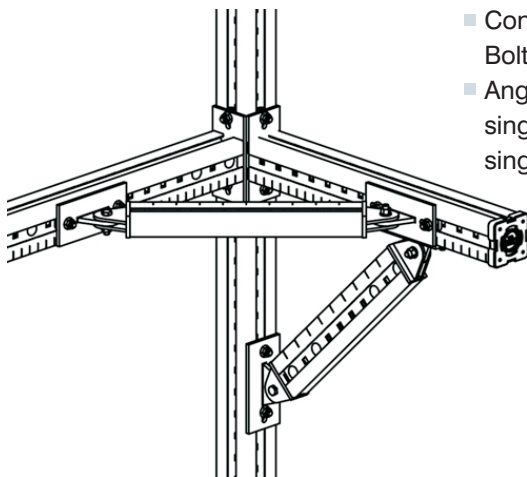

- Connection with Beam Section: With on-demand Plate, 2 x T-head Bolt ThB M12.
- Angled Pivot Joint APJ S50 can enforce the loading ability of single-arm cantilever in the vertical direction, and can assist the single-arm cantilever in resisting the horizontal impact force.

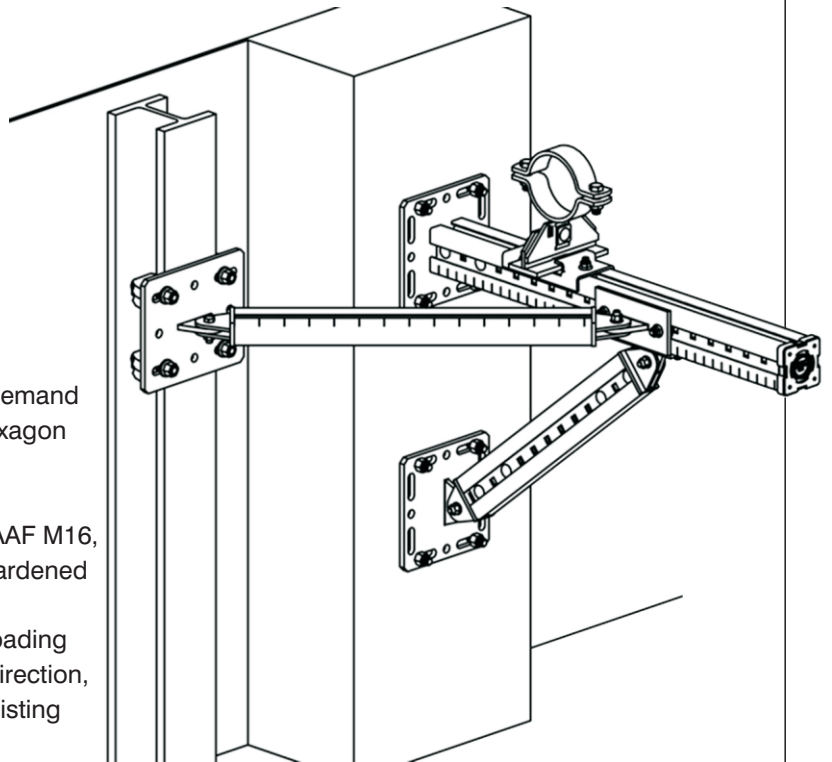

- Connection with building structure: With on-demand BP, 4xsuitable wall anchors and 4xsuitable hexagon nut.
- Connection with traditional steel beam: With on-demand BP, 4xGirder Clamps Type AAF M16, 4xM16 DTI Washers(ASEM B 18.2.6)and 4xHardened steel washers(ASTM F436).
- Angled Pivot Joint APJ S50 can enforce the loading ability of single-arm cantilever in the vertical direction, and can assist the single-arm cantilever in resisting the horizontal impact force.

➤ Additionally all size of Base Plate can be used to connect with building structure.